

TODD KNOTSON DESIGN

40 SOUTH 7th STREET
STUDIO 212-156
MINNEAPOLIS, MN. 55402
P: 612-251-1041
F: 612-552-4119
WWW.TODDKNOTSONDESIGN.COM

TERMS:

CONTRACTOR TO VERIFY ALL DIMENSIONS, AS BUILT CONDITIONS (IF APPLY) AND SITE CONDITIONS, BEFORE ORDERING MATERIAL OR DEMOLISHING EXISTING STRUCTURES. CONTRACTOR AND ALL SUBS MUST REPORT ANY DISCREPANCIES TO DESIGNER IMMEDIATELY. AS BUILT AND SITE CONDITIONS OFTEN HAVE UNIQUE CONDITIONS THAT CANNOT BE PREDICTED OR FORSEEN AT DESIGN COMPLETION. CONTRACTOR, SUBS AND DESIGNER WILL WORK TOGETHER TO REACH A SOLUTION IF ANY SITUATION MAY ARISE.

2200 EDGEcombe

JOB NO: 2200

SHEET NO:

A8

DETAILS

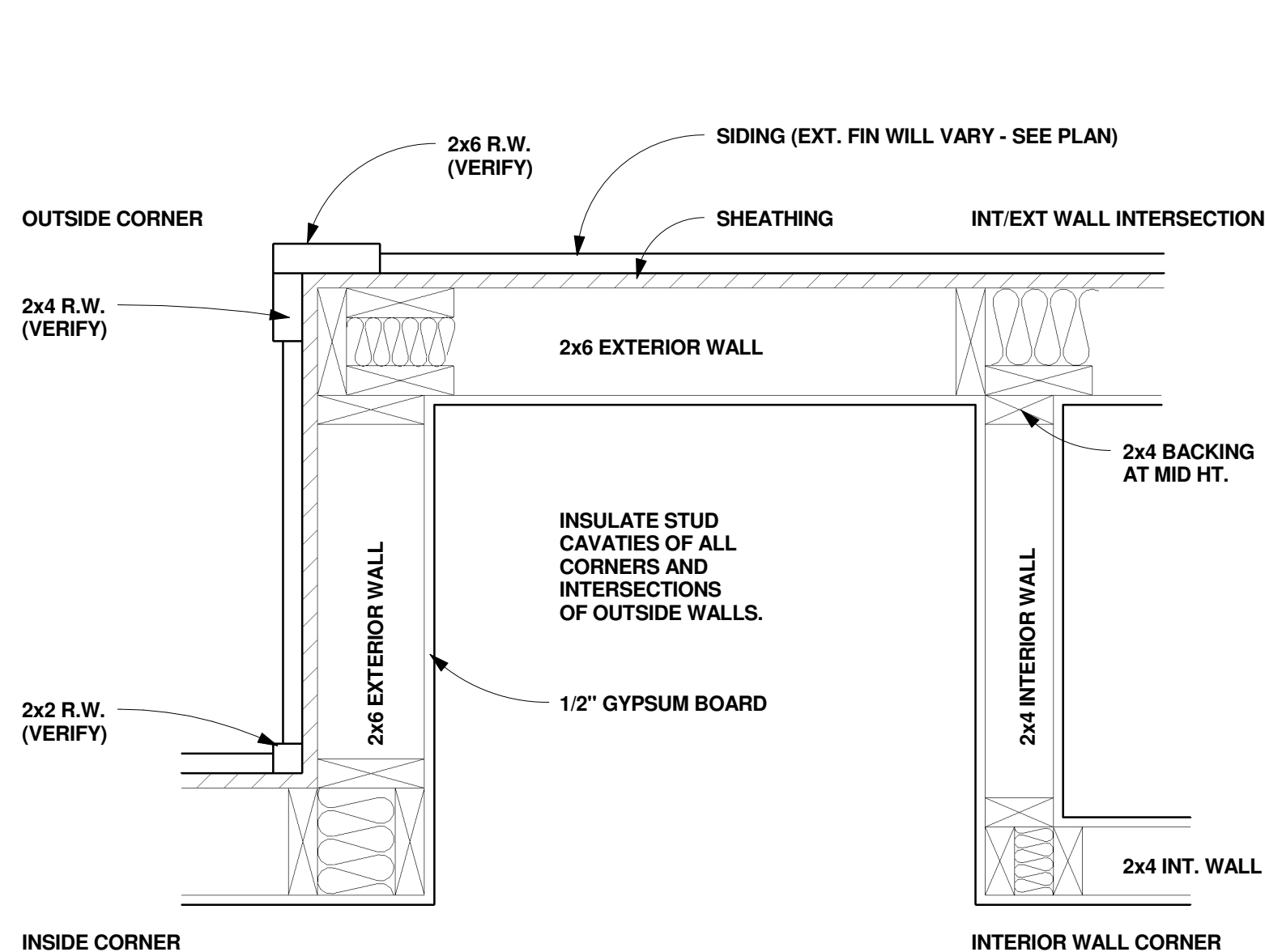

3 TYPICAL FRAMING DETAIL
A8 1 1/2" = 1'-0"

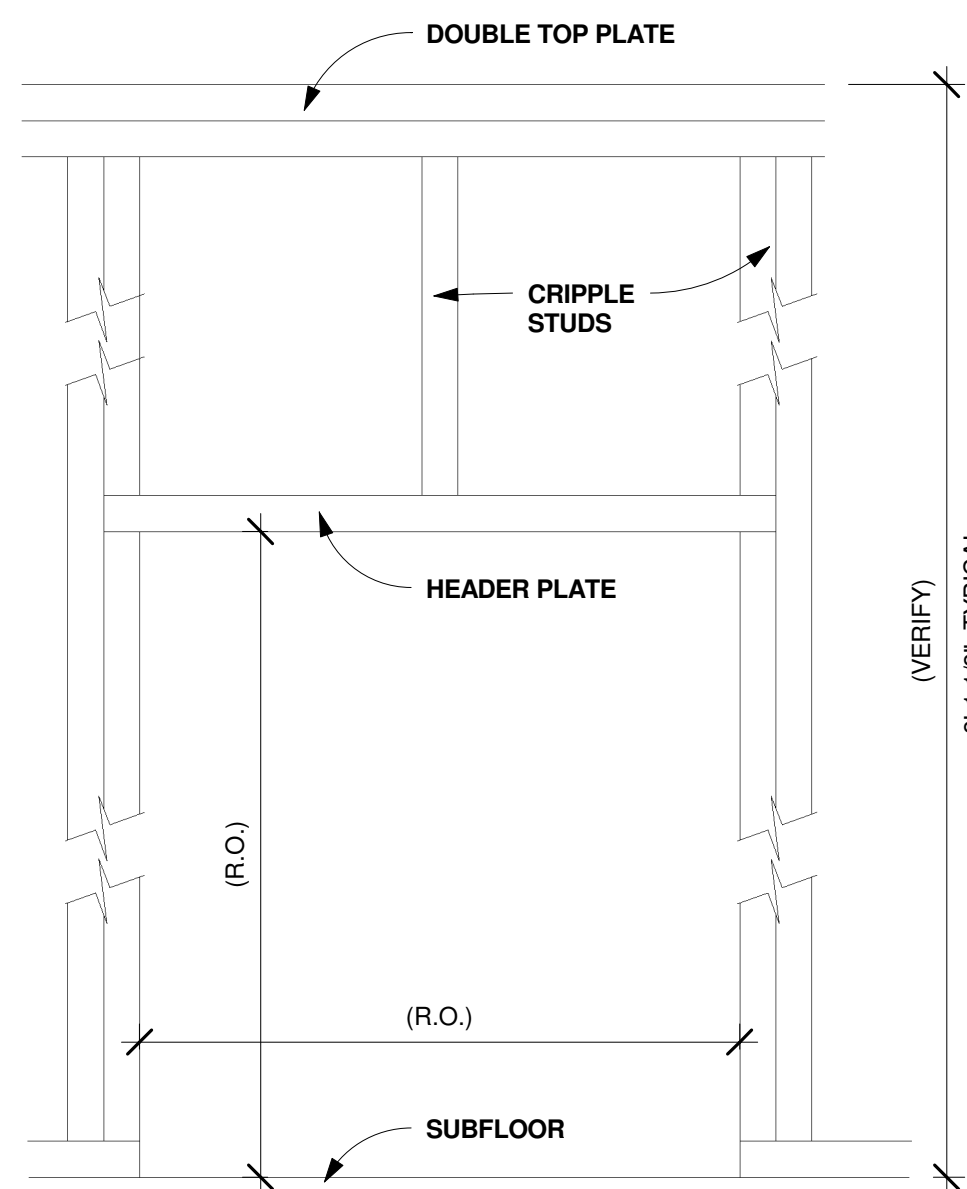

2 DOOR FRAMING DETAIL
A8 1 1/2" = 1'-0"

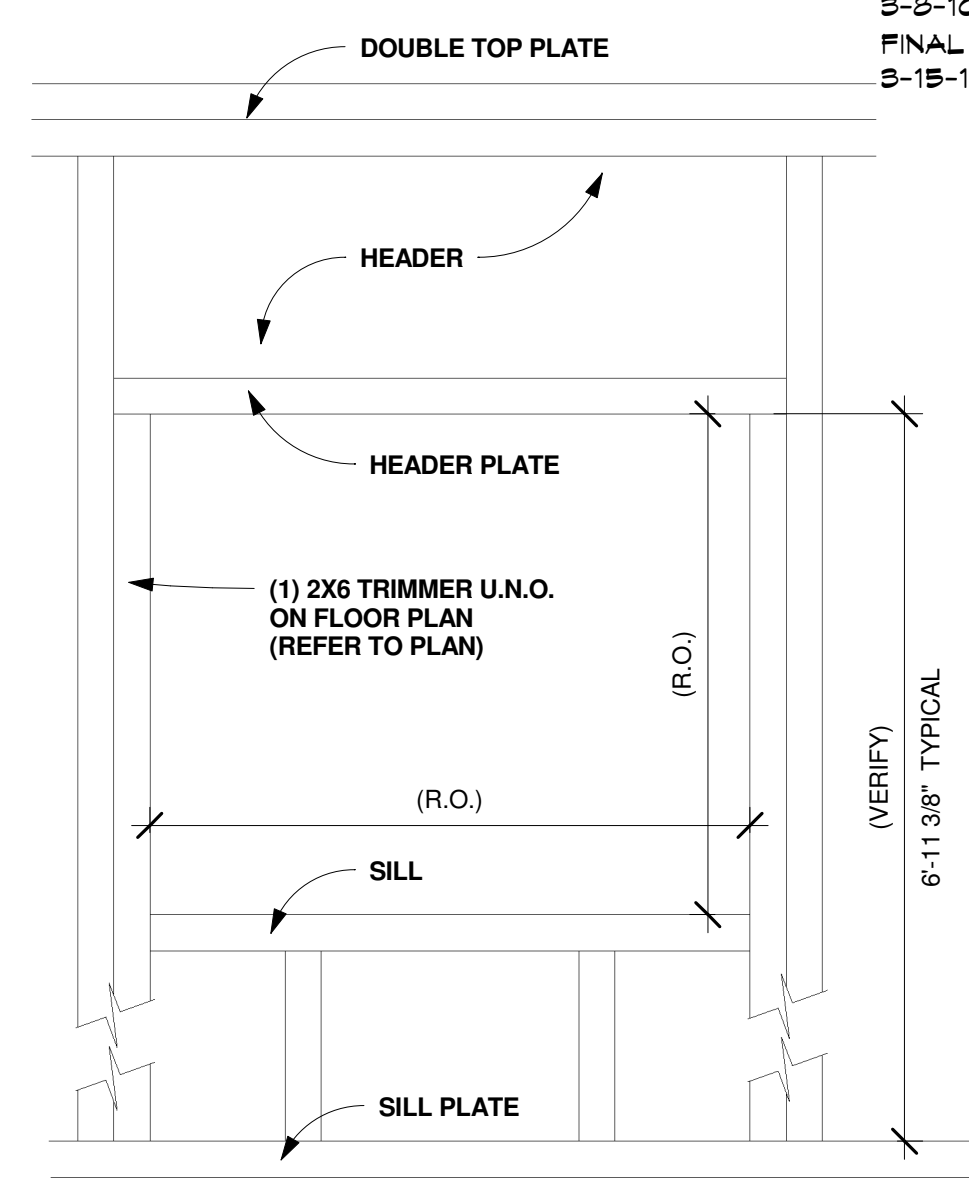

1 WINDOW FRAMING DETAIL
A8 1 1/2" = 1'-0"

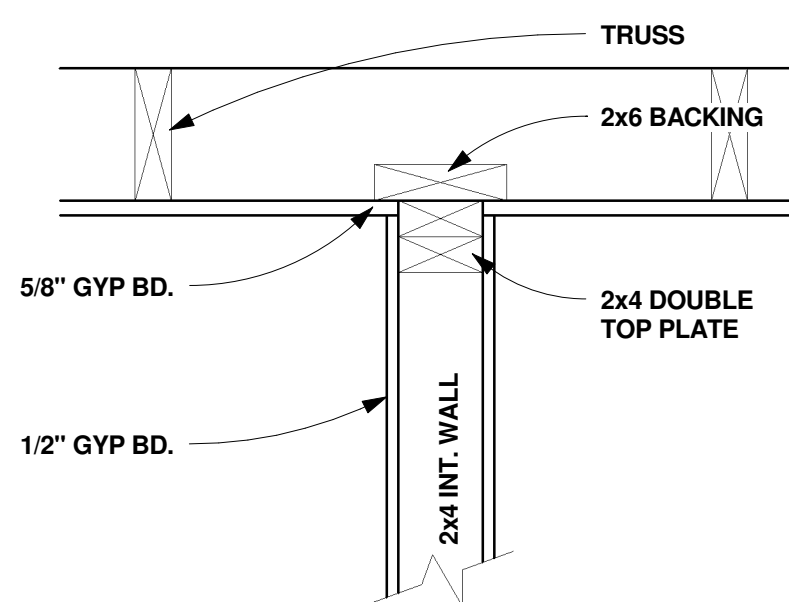

6 DETAIL AT CORNER
NAILER
A8 1 1/2" = 1'-0"

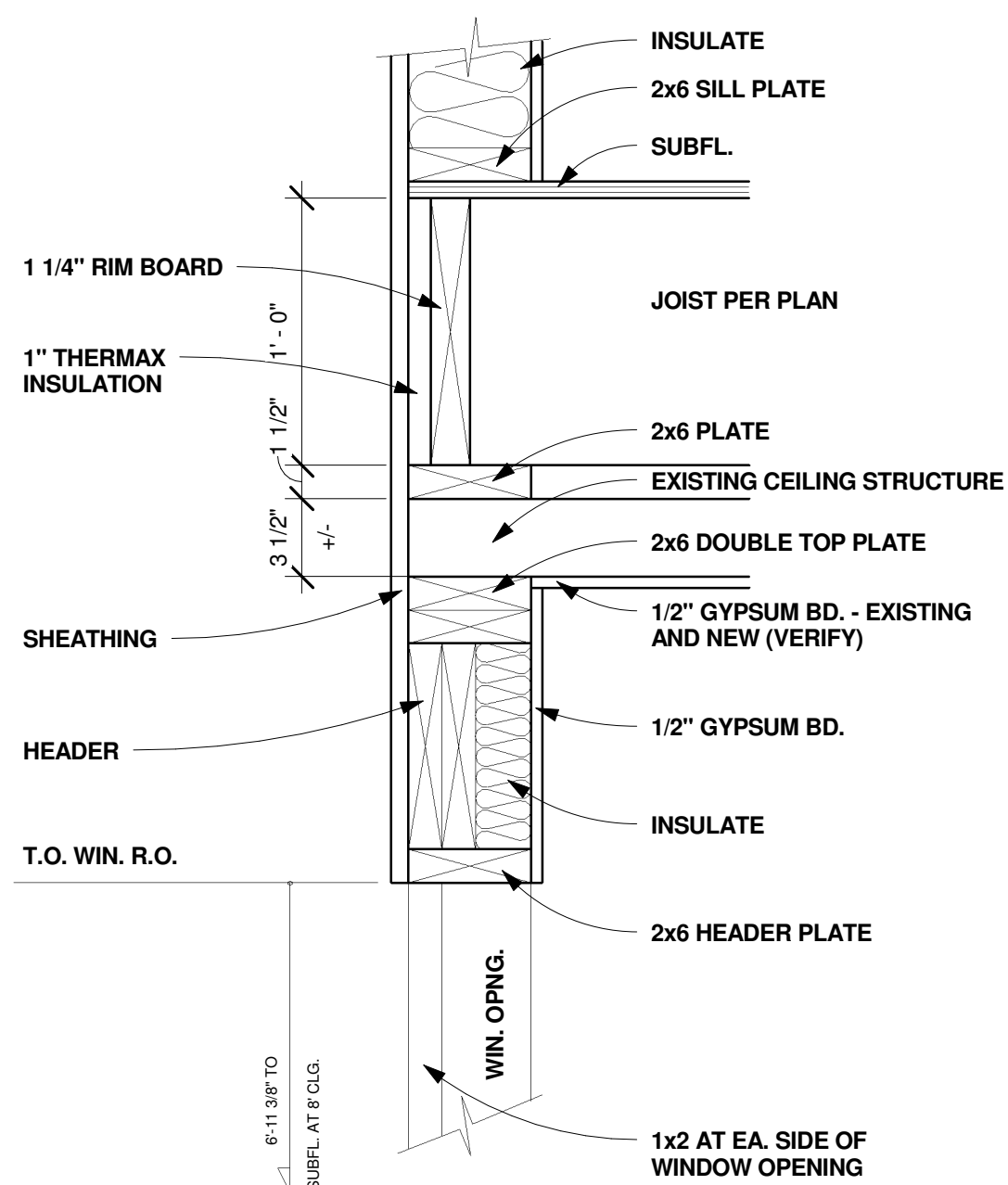

5 DETAIL AT TYPICAL
HEADER
A8 1 1/2" = 1'-0"

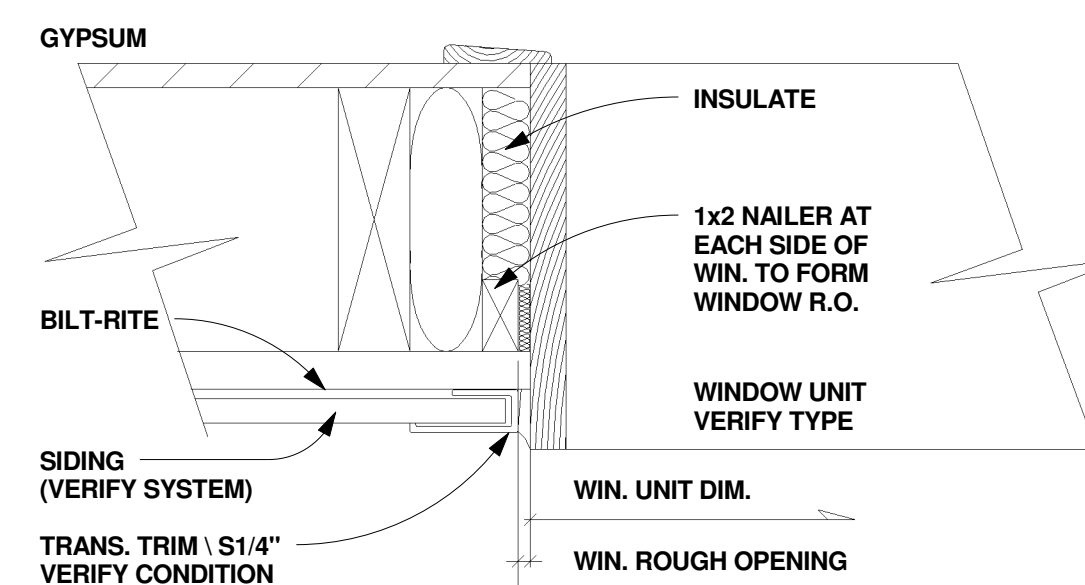

4 DETAIL AT WINDOW
NAILER
A8 3" = 1'-0"

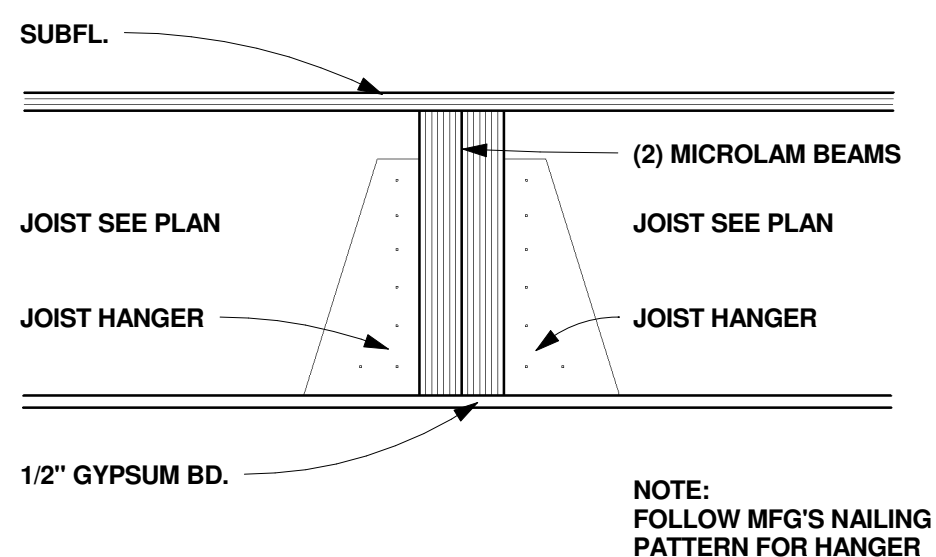

8 DETAIL AT FLUSH HEADER
A8 1 1/2" = 1'-0"

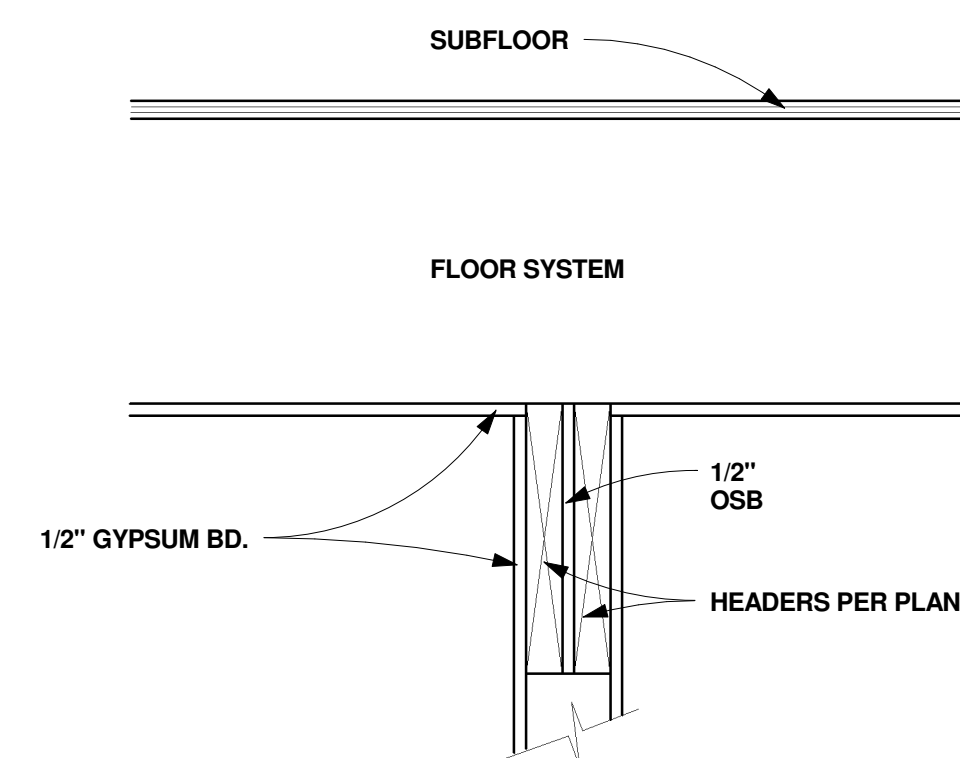

7 DETAIL AT DROPPED
HEADER
A8 1 1/2" = 1'-0"