

DATE: 4-6-2010

REVISIONS:

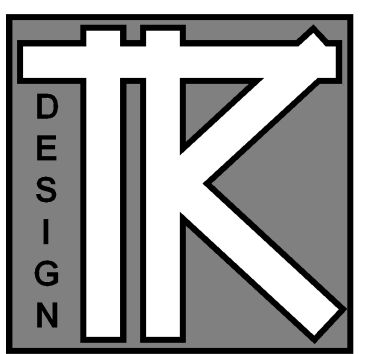

TODD KNOTSON DESIGN

40 SOUTH 7th STREET
STUDIO 212-156
MINNEAPOLIS, MN. 55402
P: 612-251-1041
F: 612-552-4119
WWW.TODDKNOTSONDESIGN.COM

TERMS:

CONTRACTOR TO VERIFY ALL DIMENSIONS, AS BUILT CONDITIONS (IF APPLY) AND SITE CONDITIONS, BEFORE ORDERING MATERIAL OR DEMOLISHING EXISTING STRUCTURES. CONTRACTOR AND ALL SUBS MUST REPORT ANY DISCREPANCIES TO DESIGNER IMMEDIATELY, AS BUILT AND SITE CONDITIONS OFTEN HAVE UNIQUE CONDITIONS THAT CANNOT BE PREDICTED OR FORSEEN AT DESIGN COMPLETION. CONTRACTOR, SUBS AND DESIGNER WILL WORK TOGETHER TO REACH A SOLUTION IF ANY SITUATION MAY ARISE.

DIETRICH REMODEL

5245 RICHWOOD DR.
EDINA, MN. 55436

JOB NO: 02XX

SHEET NO:

A7

DETAILS

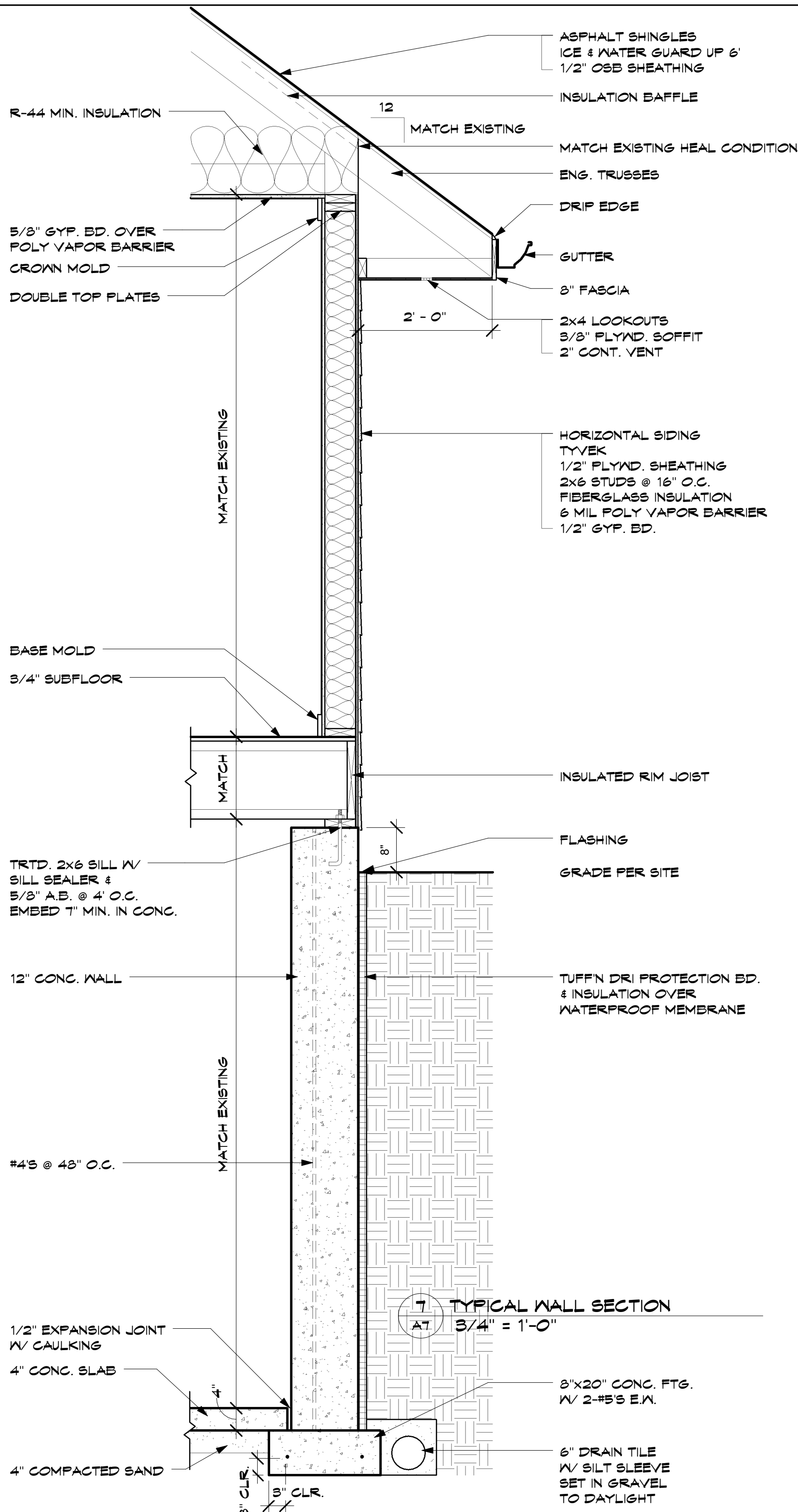

1 DETAIL AT EAVE
A7 1 1/2" = 1'-0"

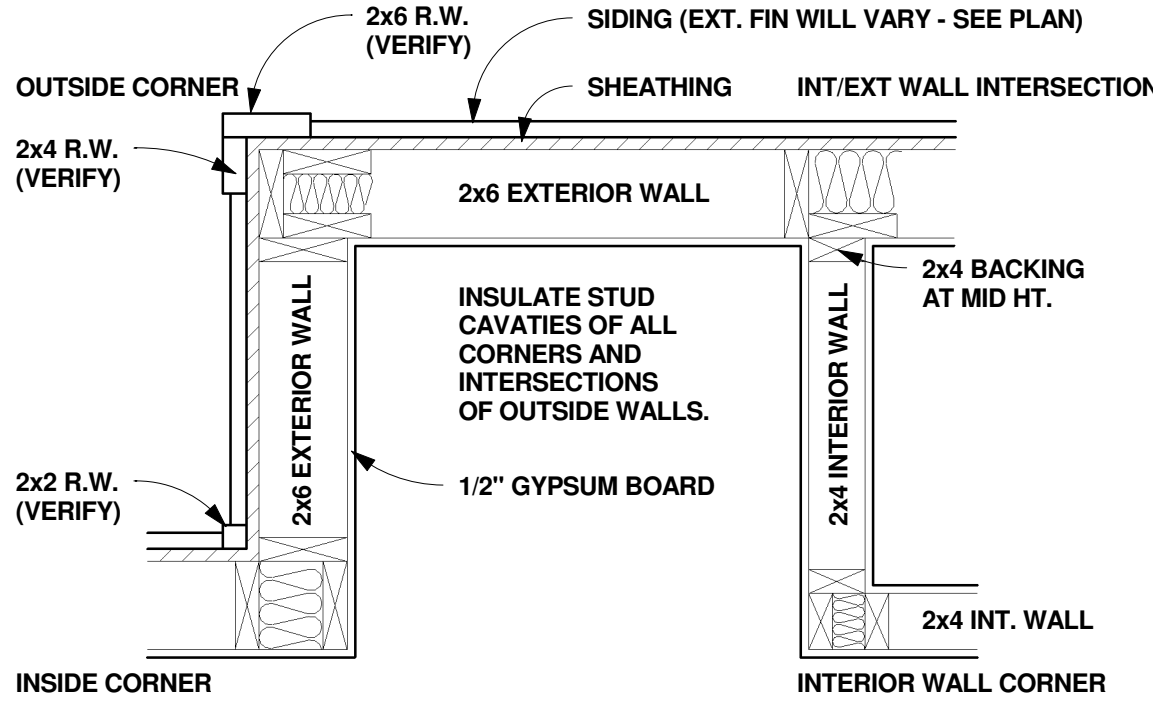
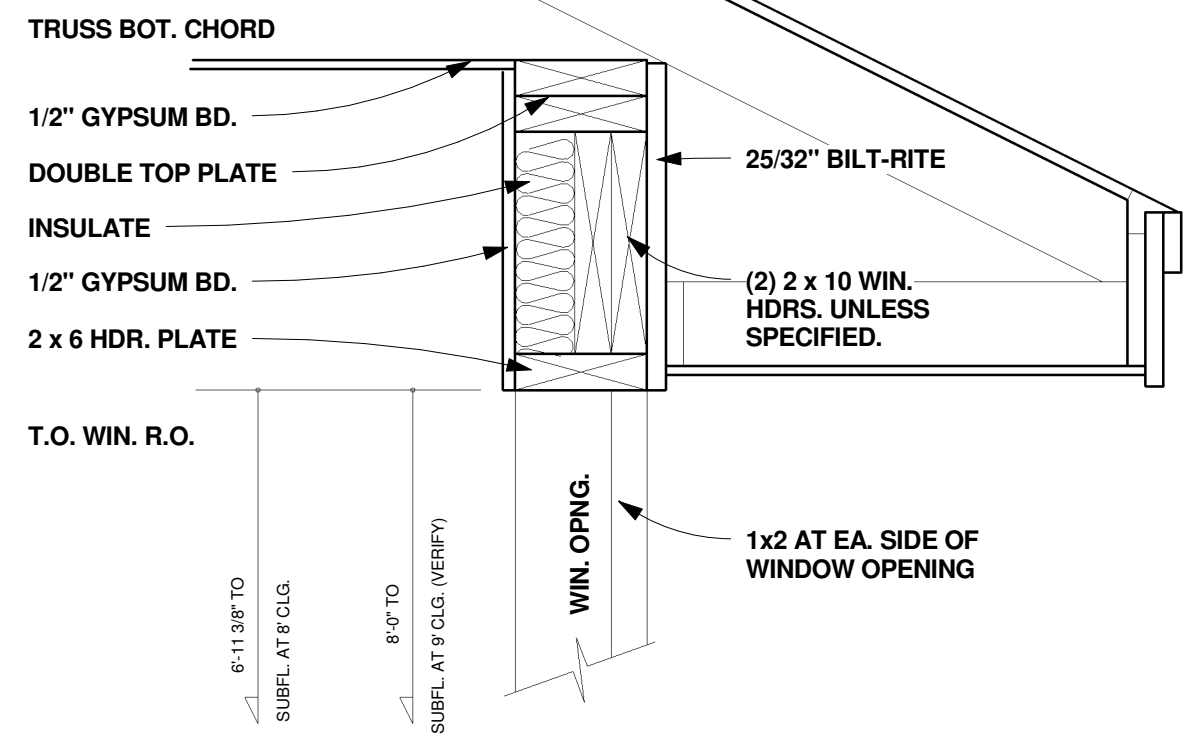

6 TYPICAL FRAMING DETAIL
A7 1" = 1'-0"

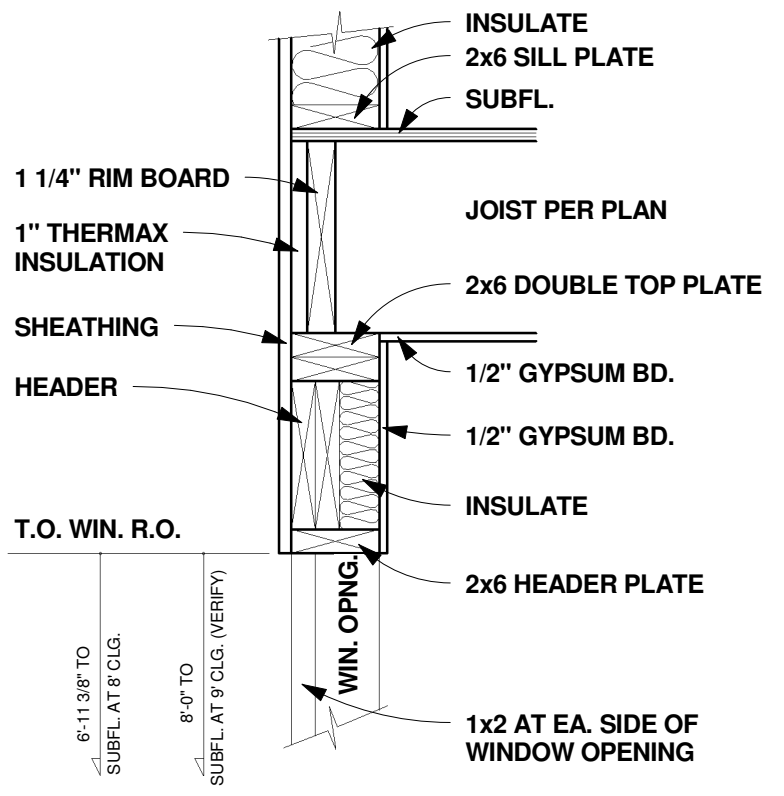

2 DETAIL AT TYPICAL HEADER
A7 1" = 1'-0"

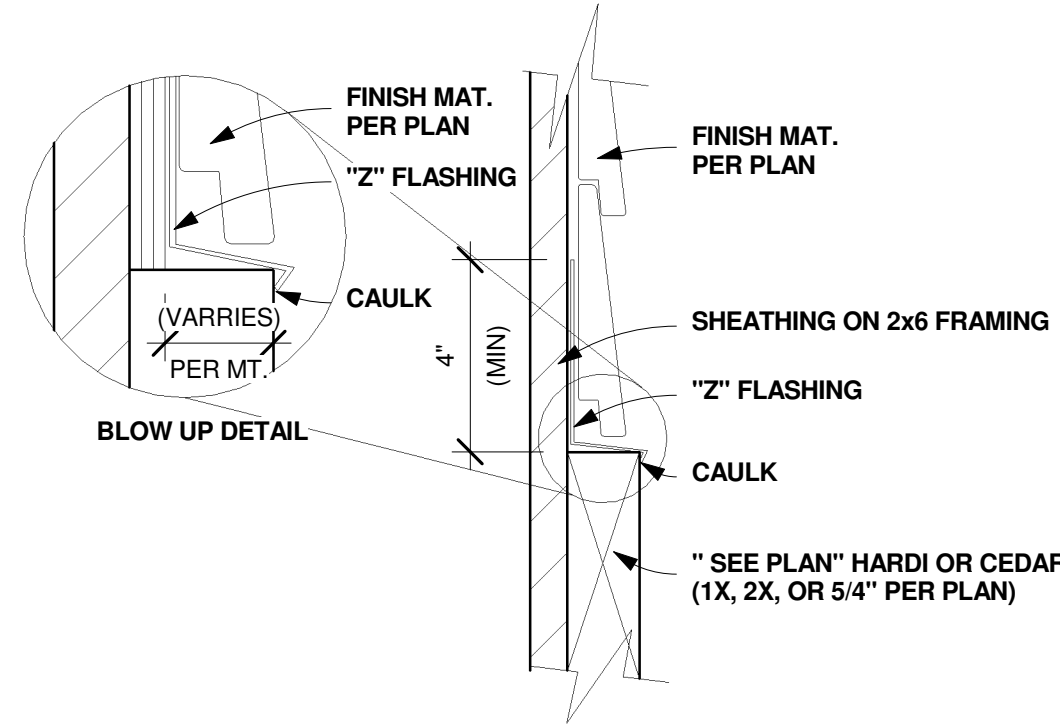

5 FLASHING DETAIL AT TRIM
A7 3" = 1'-0"

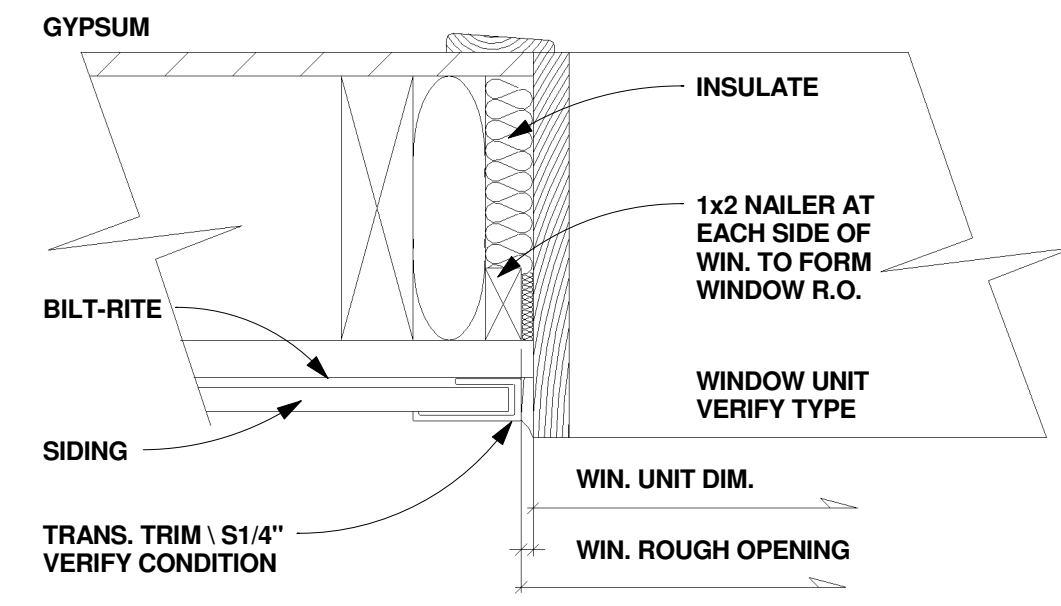

3 DETAIL AT WINDOW NAILER
A7 3" = 1'-0"

4/19/2010 4:02:42 AM